

CTB Hose Clamps - Constant Tension Band

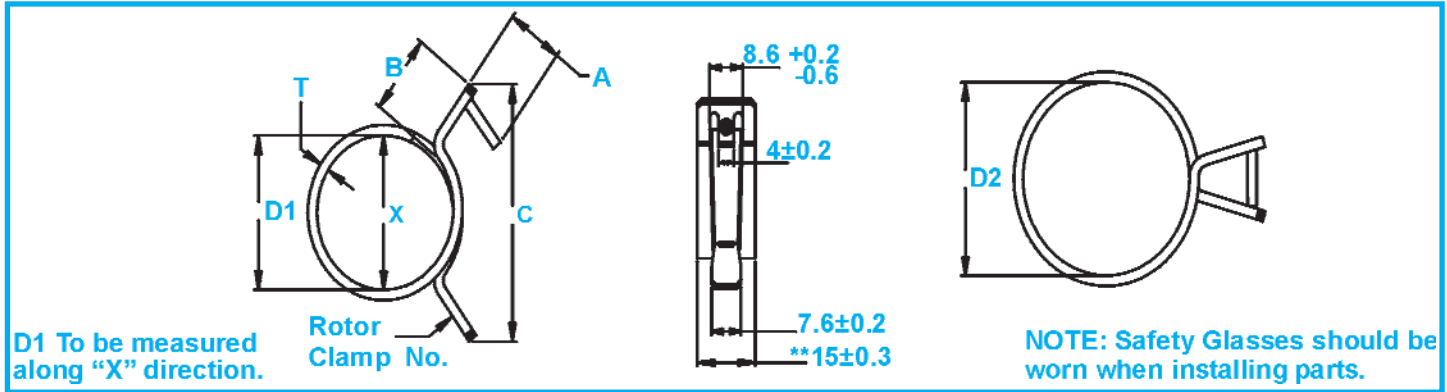
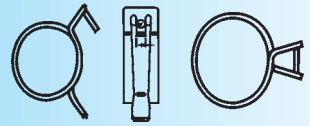

CTB Clamps should be installed/removed using the proper tool.

** Contact manufacturer for availability of additional widths.

Note: Dimensions "D1" and "C" to be measured only after expanding the clamp fully one time.

FINISH: Zinc Rich Paint* up to 700 hour-salt spray.

MATERIAL: SAE 1074 - material code ST, (Optional Material: Chrome Vanadium - DIN 17222, JIS G 4802 - material code CV.)

Note: All Dimensions are in Millimeters. Conforms to SAE spec. J1508.

Rotor Clamp CTB No. (mm)	Case Qty. min 1 case	Weight Per m (lbs.)	Weight Per Case (lbs.)	D1 Free Dia. Max. (mm)	D2 Full Open Dia. Min. (mm)	Material Thickness T 0.08 -0.02	Reference Dimensions (All Sizes Listed in mm)		
							A (mm) Tab Height	B (mm) Ear Length	C (mm) Ear Span
CTB-13	2500	8.5	21.250	12.0	14.2	0.70	7.3	11.7	27.0
CTB-14	2500	10.2	25.500	13.5	15.3	0.80	8.0	12.5	30.0
CTB-15	2500	9.35	23.375	13.9	16.8	0.70	7.2	11.9	31.0
CTB-16	2500	12.87	32.175	14.4	17.2	1.00	6.6	10.8	28.5
CTB-17	2500	10.8	27.000	15.2	18.5	0.85	7.3	12.5	32.0
CTB-19	1800	20.3	36.540	17.8	20.0	1.30	10.4	12.0	35.0
CTB-20	1700	21.4	36.380	18.4	21.6	1.30	9.1	12.1	32.0
CTB-22	1500	23.2	34.755	20.5	24.5	1.30	8.5	12.5	36.0
CTB-23	1000	27.5	27.500	21.0	24.7	1.50	8.1	12.9	39.0
CTB-24	1250	24.0	29.975	22.0	26.0	1.30	8.1	12.7	36.0
CTB-25	1000	29.5	29.500	23.5	26.8	1.50	9.3	12.4	34.0
CTB-26	1000	31.9	31.900	24.3	28.0	1.60	10.0	12.6	34.0
CTB-27	1000	33.6	33.570	25.2	28.9	1.60	10.1	12.5	38.0
CTB-29	900	38.9	35.010	27.0	31.5	1.73	10.3	13.3	35.0
CTB-30	900	38.2	34.380	28.0	32.5	1.73	11.4	13.4	41.0
CTB-32	700	38.9	27.230	29.3	34.5	1.73	11.7	12.1	44.0
CTB-35	700	44.2	30.940	31.5	38.0	1.73	11.1	15.0	50.0
CTB-36	700	44.4	31.080	32.5	39.0	1.73	11.3	13.3	48.0
CTB-38	600	47.5	28.500	34.5	41.5	1.73	10.2	15.1	52.0
CTB-40	600	47.9	28.740	35.5	42.5	1.73	11.1	13.0	52.0
CTB-42	500	54.0	27.000	37.2	44.5	1.90	10.6	14.7	52.0
CTB-44	500	56.1	28.050	38.5	46.5	1.90	11.0	14.5	53.0
CTB-46	500	61.4	30.675	40.5	48.5	2.00	11.5	14.4	55.0
CTB-47	450	63.5	28.575	41.4	50.0	2.00	13.2	14.3	59.0
CTB-50	450	67.1	30.195	43.5	53.0	2.00	11.3	14.4	59.0
CTB-51	350	67.4	23.590	44.0	54.0	2.00	11.2	15.6	60.0
CTB-53	300	77.8	23.340	46.0	55.8	2.20	11.1	16.5	61.0
CTB-55	250	79.0	19.750	46.8	58.0	2.20	11.3	15.2	65.0
CTB-58	250	85.1	21.275	50.0	61.0	2.25	10.5	14.8	66.0
CTB-61	200	98.9	19.780	54.0	65.0	2.40	12.2	15.0	69.0
CTB-67	175	108.5	18.988	60.0	72.0	2.40	13.1	16.0	78.0

* A Dorrflake finish offers five times the corrosion protection over traditional zinc plating. It is available in Black, Silver, Brown, Tan, Blue, Green and Red (Mechanical Zinc is also available along with other finishes. Inquire for more information).

Dorrflake meets the following automotive specifications: General Motors: GM-7111-M; GM-7112-M;

Ford Motor Company: ESA-M21P5A; Ford World Wide: WSD-21P11-B1, WSD-21P11-B2; Chrysler Corporation: PS-7626.

For Technical Assistance, Call 1-800-55-ROTOR
(1-800-557-6867)